

CASE STUDY

AneCom AeroTest GmbH

Germany

Aerospace

Quality Assurance

PULSE™, CIC Technology, Transducers, Conditioning

© 2006 Brüel & Kjær Sound & Vibration Measurement A/S. All rights reserved.

The development of gas turbines (jet engines) presents many technological and time-related challenges. A key component in every gas turbine is the compressor, which increases the pressure of the air entering the combustors. Compressor test and qualification is a highly specialised task that can benefit from outsourcing.



Photos by courtesy of AneCom AeroTest GmbH

AneCom AeroTest GmbH

AneCom AeroTest was founded in 2002 and is located in the aerospace test centre in the small village of Wildau just south of Berlin. It offers a one-stop solution for engineering and test services for gas turbine compressors. The initial investment in buildings and equipment exceeded of €40 M (\$50 M). Today the company has more than 80 employees.

Customers are primarily gas turbine OEMs, but AneCom AeroTest provides a wide range of specialised services for all aero-thermal components of a gas turbine like compressors, combustors, and the turbine itself. Some of these services are also offered to other industries (for example, the automotive industry).

The facility consists of three large test beds (High, Intermediate, and Low-pressure). These utilise motors up to 24000 HP, airflow up to 200 kg/s, and speeds up to 20000 RPM.

The services provided by AneCom AeroTest are:

- Design, manufacture and building of test vehicles starting from the aerodynamic definition
- Adaptation of test vehicle and test rigs to the test cells
- Design and building of all sorts of measurement rakes and aerodynamic probes
- Instrumentation design for both dynamic and static measurement parameters
- Test, data validation, and data analysis

To get an understanding of some of the challenges in a facility like this, it can be mentioned that, when operating under full load, more than 1000 litres/minute of cooling oil is circulated.

The Largest Anechoic Chamber in Europe

The low-pressure test bed is used for noise and performance investigation on engine fans. Tests are often made on scale models, which operate at higher RPM than full size models. As a result of this, the frequency range for doing scale testing is 200 Hz to 40 kHz. and the room complies with ISO 3745 Class I.

To achieve free-field conditions for measurements on large components like compressors and air turbines, the distance from the test object must be large. In the AneCom AeroTest anechoic chamber, this results in an impressive 1000 m² floor area and a height of 10 m, making this facility the largest anechoic chamber in Europe. In order to reduce airflow speed, the air inlet to the room is an impressive 8 × 10 m opening, while the outer air inlet is 10 × 5 m. The anechoic chamber (see cover picture) is equipped with 25 Brüel & Kjær Type 4191 free-field microphones mounted on 5 m high poles in a \varnothing 37 m quarter circle with the microphones facing the test object (note the diffuser for the compressor inlet on the wall). During test, the air consumption may be as large as 200 kg/s.

CIC – Charge Injection Calibration

In the aerospace industry, there can be no compromises with quality, and the integrity and accuracy of all measurements are of paramount importance. Berlin can have very cold winters and warm summers, and the environmental temperature in the anechoic chamber can change from –15 to more than +30°C. The test and control room is in a normal office environment approximately 50m from the microphone poles. To secure the quality of acoustical measurements, AneCom AeroTest use CIC (Charge Injection Calibration).

Mr. Detlef Mueller, Head of Measurement, explains, “For us it is extremely important to be able to perform fast, high-quality measurements. Using the CIC technique we are able to verify all 25 acoustic measurement channels in less than 15 minutes”. CIC is Brüel & Kjær’s patented simple yet ingenious method for verification of not only the microphone and the preamplifier, but also the complete measurement chain.

AneCom AeroTest uses microphones Type 4191 with Type 2669 preamplifiers. The microphone cable is routed to an intermediate signal station with Brüel & Kjær’s 16-channel Conditioning Amplifier Type 2694. From there the analog microphone signal is routed to the acoustic channels in the dynamic test system.

The mode control (system verification or test) and the AC signal used by CIC during verification are generated by Brüel & Kjær’s PULSE system. AneCom AeroTest performs CIC at a number of discrete frequencies ranging from 300 Hz to more than 10 kHz. Although this gives an extremely high degree of security, in many cases CIC can be performed at just one or two frequencies with sufficient fault detection security.

Quality Assurance

Fig. 1
An engineer
performing the weekly
pistonphone calibration



The AneCom AeroTest company policy states “We always achieve or exceed customer expectations/requirements particularly with regard to Quality, Cost, and Time”. Mr. Detlef Mueller explains, “Our customers are always very conscious of the acoustical measurements, so for quality assurance of the acoustical measurements a special method had to be found. Once a week we make an acoustical calibration using Brüel & Kjær’s Pistonphone Type 4228. During the calibration, an engineer has to be present in the anechoic chamber lowering the microphones and mounting

the pistonphone onto the microphones one by one. The system scans and automatically detects when the pistonphone is connected and the signal valid. The calibration factors are then stored. Following this, a CIC is performed and the CIC gain is stored”.

The basic idea in CIC is that as long as nothing has changed (which can be taken for granted if the CIC gain remains unchanged), then the last calibration is still valid.

Mr. Mueller continues, “Despite outside temperatures as low as minus fifteen in winter and up to around thirty degrees in summer, we have never really had any problems with the microphones. In fact, the acoustical measurement channels are so stable that we have been able to reach a stability of better than 0.1 dB; actually we have defined a limit of 0.1 dB change in CIC gain at which we will require a recalibration of the system. The long-term figures speak for themselves – over a period of nearly two years the change in CIC gain is typically less than 0.2 dB”.

The master CIC (green curve, Fig. 2) was done during commissioning of the system. The reference CIC (pink curve, Fig. 2) is done right after a (real) pistonphone calibration. The daily CIC is done on a daily basis or whenever proof of measurement integrity is needed. The maximum deviation between the reference CIC and the daily CIC is 0.1 dB at 1000 Hz, at higher frequencies a slightly higher value is accepted. This criterion corresponds to a reproducibility within 0.1 dB taking into consideration changes in microphone, conditioner, and A/D converter. The CIC values measured by the system are directly transmitted to Excel.

Fig. 2
 Change in CIC and
 Channel gain less than
 0.05 dB for this
 channel

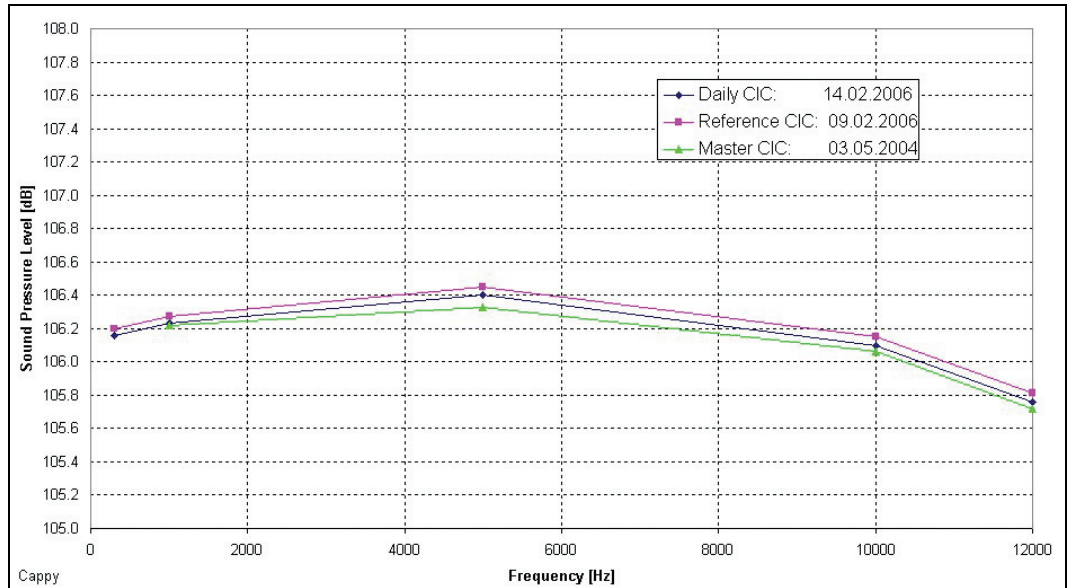

The Calibration History Chart in Fig. 3 shows the change in total system calibration factor, which is the combined change in microphone, preamplifier, cabling, conditioning and front end vs time.

Actually the microphones were also switched between different front end channels. Despite this the drift curve looks behaves well with a total combined drift factor of less than 0.3 dB/year.

Fig. 3
 Calibration History
 Chart

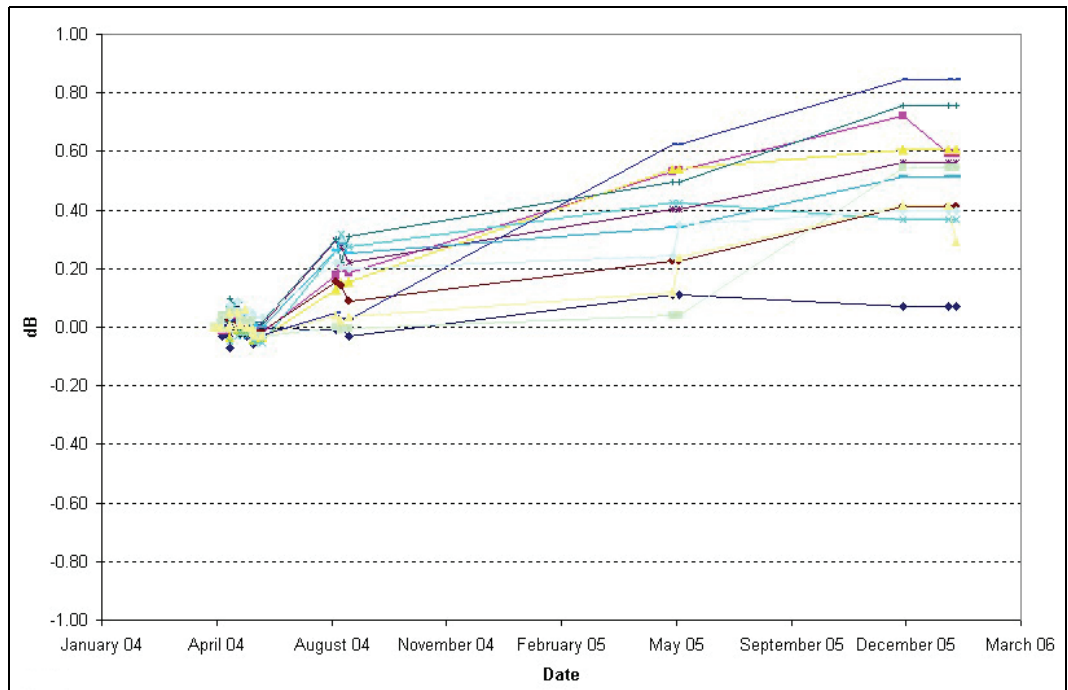

Future Plans

Fig. 4

An engineer in the test room at AneCom AeroTest sets up the PULSE system used for CIC verification of the complete measurement chain

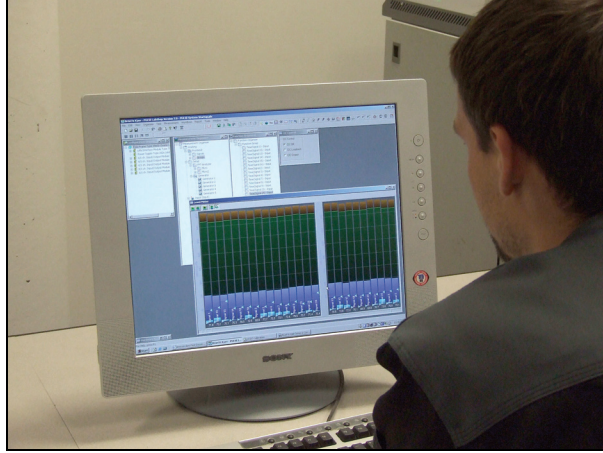

For a company like AneCom AeroTest, close cooperation with instrumentation and sensor suppliers is essential in order to improve and expand the services that can be provided. A close dialogue between AneCom AeroTest and Brüel & Kjær has resulted in the advanced CIC setup used successfully for several years. An option presently being considered is to integrate Surface Microphones – in addition to the present pressure sensors – in the compressor air inlet ring for in-depth investigation of turbulence and noise issues.

Summary

CIC has proven to be a valuable and time-saving method to secure measurement integrity. Furthermore, the method has documented a total system stability of better than 0.1 dB between calibrations, and long-term change of only a few tenths of a dB including all system elements and influence from changing environmental conditions. To conclude Mr. Mueller states, “During the whole installation process, we got a wonderful support from the Brüel & Kjær engineers”.

What is CIC and How does it Work?

The Charge Injection Calibration (CIC) technique is a method for remotely verifying the condition of the entire measurement chain including the microphone! The CIC principle is developed and patented by Brüel & Kjær. It is as simple as it is ingenious.

A small but accurately defined capacitor C_c (typically 0.2 pF), is introduced in the preamplifier (see diagram below). C_i represents the preamplifier's input capacitance and g its gain (≈ 1).

In the CIC mode an AC signal is routed to pin 1 and hence injected into the summing point of the preamplifier input. The ratio between the AC voltage on pin 4 and pin 1 is called the CIC gain. Typically this is around -40 dB. The CIC gain will change considerably, even for small changes in the microphone's capacitance C_m or any change in measurement chain.

So if the CIC gain is measured right after a real calibration is performed, then as long as the CIC gain remains constant, nothing has changed and the original (real) calibration is still valid.

The CIC technique is directly implemented in the NEXUS™ Conditioning Amplifier and can be implemented in PULSE by a small piece of software.

Normally CIC can only be used with classical preamplifiers and not with the DeltaTron® types, except for the Surface Microphones, where an additional cable connects the AC signal to the microphone.

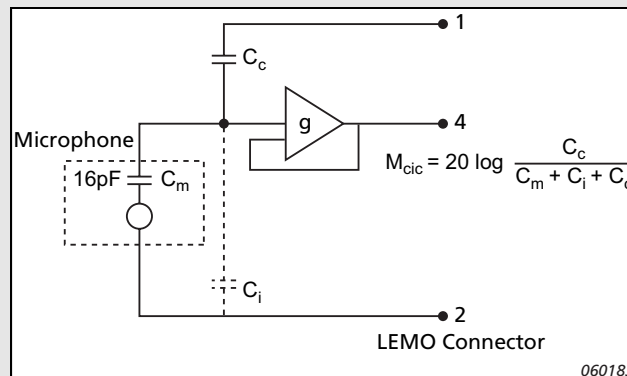

HEADQUARTERS: DK-2850 Nærum · Denmark · Telephone: +45 4580 0500 · Fax: +45 4580 1405
www.bksv.com · info@bksv.com

Australia (+61) 2 9889-8888 · Austria (+43) 1 865 74 00 · Brazil (+55) 11 5188-8161
Canada (+1) 514 695-8225 · China (+86) 10 680 29906 · Czech Republic (+420) 2 6702 1100
Finland (+358) 9-521 300 · France (+33) 1 69 90 71 00 · Germany (+49) 421 17 87 0
Hong Kong (+852) 2548 7486 · Hungary (+36) 1 215 83 05 · Ireland (+353) 1 807 4083
Italy (+39) 0257 68061 · Japan (+81) 3 5715 1612 · Republic of Korea (+82) 2 3473 0605
Netherlands (+31) 318 55 9290 · Norway (+47) 66 77 11 55 · Poland (+48) 22 816 75 56
Portugal (+351) 21 41 69 040 · Singapore (+65) 6377 4512 · Slovak Republic (+421) 25 443 0701
Spain (+34) 91 659 0820 · Sweden (+46) 33 225 622 · Switzerland (+41) 44 880 7035
Taiwan (+886) 2 2502 7255 · United Kingdom (+44) 14 38 739 000 · USA (+1) 800 332 2040

Local representatives and service organisations worldwide

Brüel & Kjær 